



# MODEL SDF

## PRODUCT CARE



### CHANGING THE DIRECTION OF RETRIEVE

1. Remove the spool (1) from the frame (2) by unscrewing the spool release cap (3), turning it counter clockwise.
2. Next remove the spindle assembly (5) by turning the knurled spindle housing (4) counter clockwise.
3. Remove the spindle assembly (5) from the frame, the roller clutch (6) should come out with the spindle assembly.
4. Remove the roller clutch (figure 6-1 / 6-2) from the spindle, flip over, and reinstall on the spindle assembly (5). Note that the clutch has writing engraved on one side.
5. If the clutch is installed with the writing facing "up," or towards the spindle assembly as shown in figure (6-1), it will be Left Hand Retrieve
6. If the clutch is installed with the writing facing "down," or away from the spindle assembly as shown in figure (6-2), it will be Right Hand Retrieve
7. Replace spindle assembly (5) in frame and tighten the spindle housing by turning clockwise.
8. Replace the spool (1) on the frame (2)

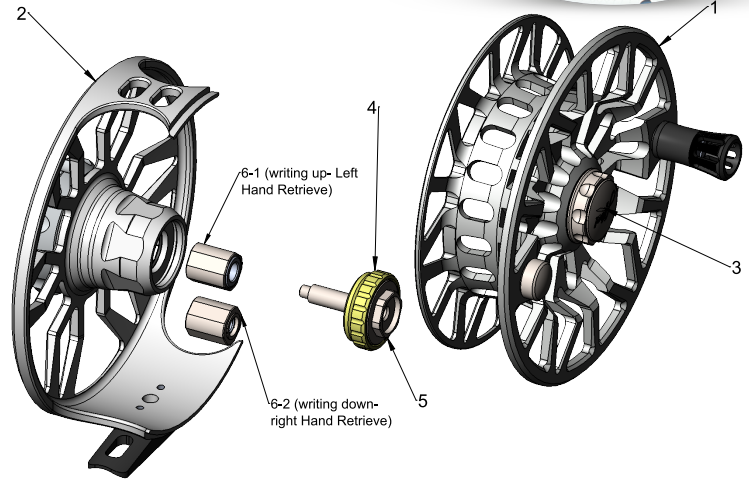

### SPECIFICATIONS

All capacity numbers are in yards. Line capacities are based on 90- foot floating fly lines and 20# backing. All numbers are conservative, as capacities will vary according to specific length and diameters of alternative line manufacturers' products. Capacities will be reduced by approximately 20% if using #30 backing instead of #20 backing.

SDF 4/5		SDF 5/6		SDF 6/7	
ARBOR SIZE	LARGE	ARBOR SIZE	LARGE	ARBOR SIZE	LARGE
REEL	\$695	REEL	\$755	REEL	\$795
SPOOL ONLY	\$420	SPOOL ONLY	\$455	SPOOL ONLY	\$480
WEIGHT	5.02 oz.	WEIGHT	5.42 oz.	WEIGHT	5.63 oz.
SPOOL DIAMETER	3.260	SPOOL DIAMETER	3.610	SPOOL DIAMETER	3.735
SPOOL WIDTH	1.120	SPOOL WIDTH	1.120	SPOOL WIDTH	1.150
LINE + YARDS OF BACKING	4 + 90 20# 5 + 75 20#	LINE + YARDS OF BACKING	5 + 125 20# 6 + 100 20#	LINE + YARDS OF BACKING	6 + 165 20# 7 + 145 20#

### CLEANING

While the Model SDF is fully anodized to protect against corrosion and the elements, we recommend that you clean your reel after each use, especially after exposure to a salt or alkali environment. Use fresh water (distilled is preferred) to flush salt and debris from the reel. For better cleaning results, separate the Spool (1) from the Frame (2), soak both in warm, fresh water (again, distilled is preferred) and then rinse in fresh running water. Please note there is no need to dismantle or clean the drag system as it comes fully sealed from our factory. Let the Spool (1) and the Frame (2) dry completely before putting together and storing. We recommend allowing them to air dry with both the face of the spool (front) and the drag-knob-side of the frame facing up on a towel.

### NO LUBRICATION IS NECESSARY

The Model SDF has a fully sealed drag system, and DOES NOT REQUIRE LUBRICATION. Any squeaking, or related noises will likely be the result of dirt or particulates building up on the frame and spool, and in this case, cleaning as outlined above should solve this issue. Please also note any modifications to the reel can result in the voiding of the lifetime warranty.